

# Soleo 6027

**Geolam**<sup>®</sup>  
Architectural Eco-Technology

## Hybrid Aluminum/WPC Architectural Elements

Datasheet

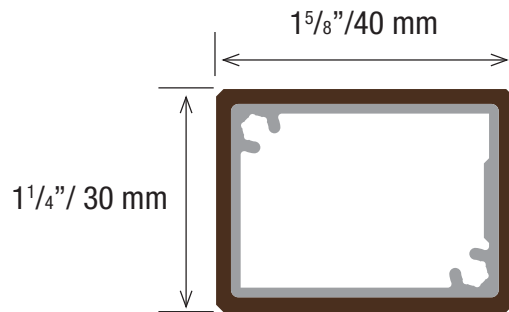

**Thickness:** 30 mm | 1 1/4 in

**Width:** 40 mm | 1 1/2 in

**Section tolerances in mm:** + 0.5 / - 2.0

**Fire rating:**

On request before order

**Surfaces finish:** sanded

**Standard length:** 3.00 m | 9 ft 10 in

**Or order any length from:**  
2.45 m | 8 ft to 5.48 m | 18 ft

**Weight:** 0.74 kg/lm | 0.49 lb/ft

**Secondary moment Ix (cm<sup>4</sup>):** 1.89

**Secondary moment Iy (cm<sup>4</sup>):** 3.44

**Section modulus Zx (cm<sup>3</sup>):** 1.45

**Section modulus Zy (cm<sup>3</sup>):** 1.99

**Core in anodized aluminum alloy:**

A6063S-T5

**Coefficient of Thermal Expansion:**

(20-100°C) : 23.4 µm/m/°C

**Modulus of Elasticity:** 68.6 GPa

**Tensile Strength:** 186 Mpa min

**Core cross section (mm<sup>2</sup>):** 182.08

**Standard Colors** - Minimum 1,000 ft for all colors:



Teak



Moleskin



Rosewood



Ebony

**Non-Standard Colors** - 90 day lead time - Minimum order quantities apply:

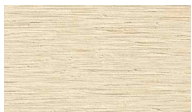

Ivory



Blackwood

**Custom Colors Available** for orders >6,000 sq. ft.

[www.geolaminc.com](http://www.geolaminc.com)  
Toll free: 1-877-627-3530  
[info@geolaminc.com](mailto:info@geolaminc.com)